



GAS CONVECTION OVEN

Features

- 3 inshot burners, 18,000 BTU each-total 54,000 BTU
- Electronic thermostat (FAST) & manual timer control
- Temperature range: 150°-500°F (66°-260°C)
- Independent doors with full view windows
- 2-speed, ½ HP fan motors (1725, 1140rpm) for even heat distribution and forced "cool down" fan mode
- Porcelain enamel oven interior for easy cleaning
- Stainless steel front, sides & top exterior
- 5 nickel plated Heavy Duty racks, 11 rack positions
- **Available in Natural gas(NG) or Liquid propane(LP)**
- **A conversion kit is supplied with each unit**



VGCO



VGCO-2



GAS CONVECTION OVEN

Dimensions in inches (mm)

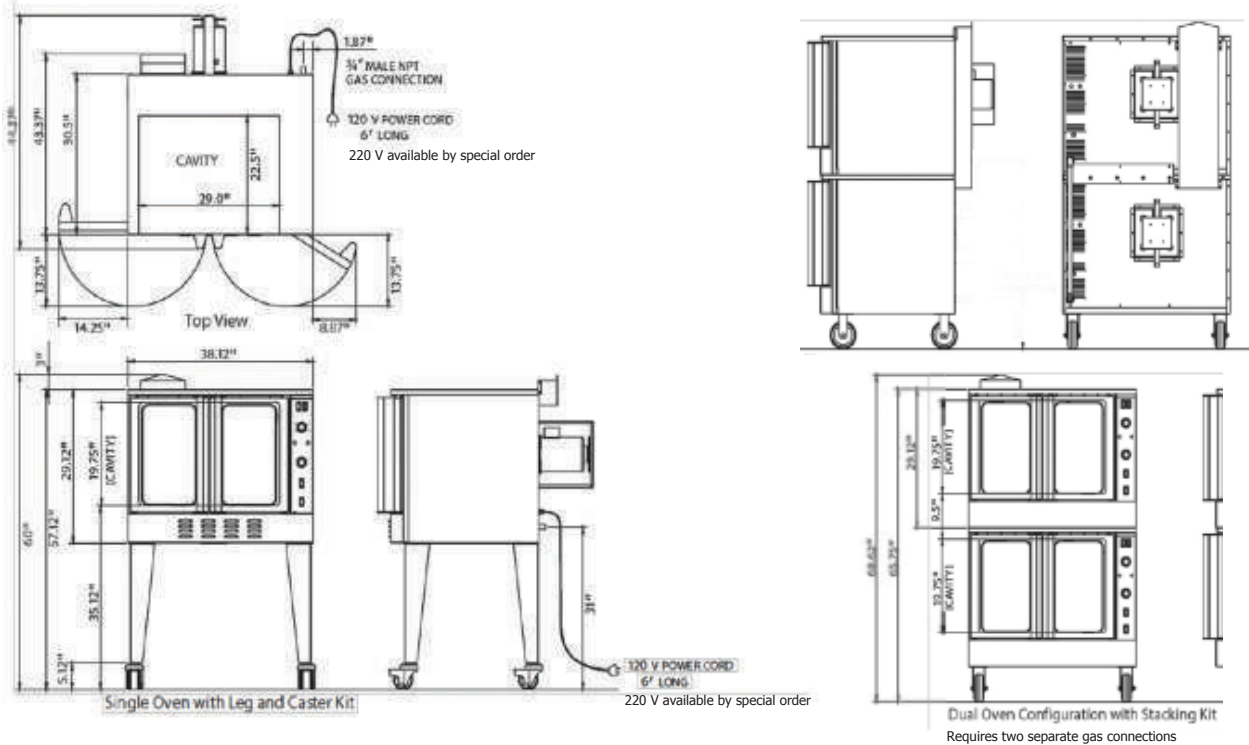

Specifications

Model	Overall Dimensions	Oven Interior	Rack Clearance	Shipping Crate(s)
VGCO	38.12"W x 44.37"D x 60"H (96.8cm x 112.7cm x 152.4cm)	29" W x 22.5" D x 19.37" H (74cm x 57cm x 50cm)	28"W x 21"D (72cm x 53.3cm)	45.3"W x 49.2" D x 37" H, 48 cu ft., 511 lbs (115cm x 125cm x 99cm, 1.35 cu m., 232kgs)
VGCO-2	38.12"W x 44.37"D x 65.62"H (96.8cm x 112.7cm x 166.7cm)	29" W x 22.5" D x 19.37" H (74cm x 57cm x 50cm)	28"W x 21"D (72cm x 53.3cm)	2 Single Oven Crates, Total, 96cu ft., 1022 lbs. (2.7cu m., 464kgs.)

GAS REQUIREMENTS

- Natural Gas or Liquid Propane (LP) Gas main supply required
- A conversion kit is supplied with each unit. In order to avoid any warranty issues, conversion of your unit must be completed by an authorized Ikon service agent.
- 3/4" NPT gas connection
VGCO-2 requires two gas connections
- Natural gas 3.5" W.C., LP gas 10" W.C.
- VGCO Includes leg and caster kit
- VGCO-2 Includes stacking kit

Leg or Stacking Kits	Shipping Carton	Weight
VGCO SINGLE	29.9"W x 18.1"D x 8.7"H	41lb
LEG AND CASTER KIT	(76cm x 46cm x 22cm)	18.5kg
VGCO DUAL	38.2"W x 11.8"D x 6.7"H	35lb
STACKING KIT	(97cm x 30cm x 17cm)	16kg

