

Countertop Gas Range

PROJECT:

ITEM NUMBER:

MODEL NUMBER:

SPECIFICATIONS FOR: HP24

- **Size:** Available in 1 size, HP24 is 24"
- **Finish:** Heavy Duty cast iron burners, stainless steel exterior
- **Hardware:** Cast iron burners with easy to clean lift off top, removable burner grates, cool to touch front edge, removable grease catch pan, adjustable non-skid stainless steel legs
- **Connections:** Pressure regulator is provided with the unit; LP conversion kit is included
- Pressure for Natural Gas- 4" Propane -10", Gas connection is 3/4" NPT (19mm) rear gas connection
- **Instrumentation:** Large individual burner knobs with set screw
- **Approvals:** ETL, cETLus

STANDARD FEATURES

- LP conversion kit included
- Available with 4 burners, each with 25,000 BTUs
- Available in 24"
- High performance heavy cast iron burners
- Heavy Duty removable burner grates
- Adjustable non-skid stainless steel legs
- Each burner has its own adjustable pilot
- Extended cool to touch front edge
- Removable, easy to clean stainless grease catch pan
- Large temperature knobs with set screws
- 1 Year Parts & Labor
- ETL, cETLus

WARRANTIES



Parts & Labor

** C-UL is Underwriters Laboratories Safety Certification Mark which indicates that UL has tested the equipment to applicable CSA Standards.

** UL-Sanitation is Underwriters Laboratories Safety Certification Mark which indicates that UL has tested the equipment to applicable NSF Standards.



HP-24

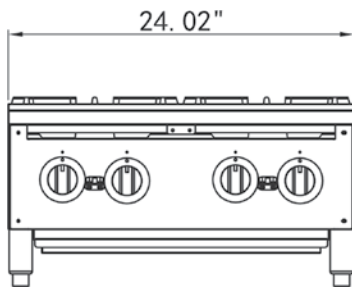
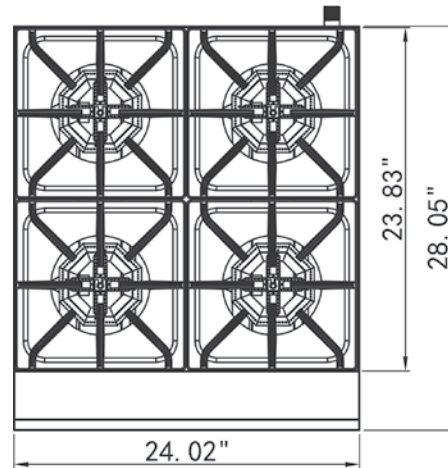
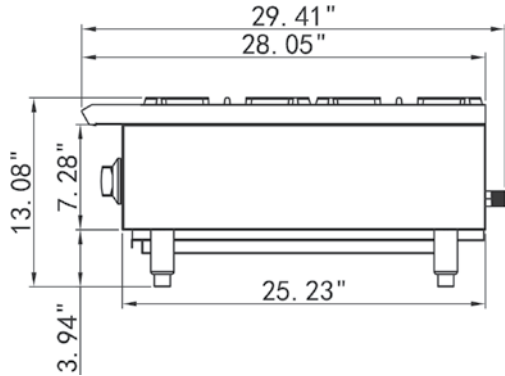

SPECIFICATIONS

Models	HP-24
Burners	4
Width	24
Depth	28.05
Height	13
BTU's (per burner)	25,000
Total BTU's	100,000
Crated Weight (lbs)	168

Distributed by:



Rapids Wholesale Equipment
6201 S Gateway Dr.
Marion, IA 52302

Specifications subject to change without notice.

Specifications subject to change without notice.

Revision Date: 06/18