

## E-Series Bottle Coolers



### SPECIFICATIONS FOR: BST50 and BST65

- **Exterior Finish:** Stainless steel external top and side, steel painted black back, stainless steel doors
- **Interior Finish:** 304 stainless steel
- **Insulation:** Polyurethane (CFC Free)
- **Hardware:** Standard with bottle opener cap catcher, integrated glass rail on rear top, easy glide sliding lids with locks. Adjustable product dividers supplied. (4) 1" fixed rollers. LED lighting.
- **Electrical:** 115 volt, 60 Hz, 1 phase with cord and NEMA 5-15P plug.
- **Refrigeration:** CFC free refrigerant and foam with self-contained capillary tube system  
Self-defrosting evaporator. R600a refrigerant.  
Adjustable temperature control with temperature range: +34°F to +38°F.
- **Approvals:** UL, C-UL Safety. Certified for ANSI/NSF7 Standards (US & Canada) \*\*

### STANDARD FEATURES

- Adjustable temperature control
- Air cooled condensing unit
- Automatic defrost and condensate evaporator
- Black coated steel exterior
- Capillary tube system
- Durable stainless steel interior walls
- Cap catcher
- LED Lighting
- Stainless steel top
- Stainless steel interior floor
- Stainless steel sliding lids
- Temperature range: +34°F to +38°F
- Epoxy coated product dividers
- 2 Year Parts & Labor, 3 Year Compressor Warranty
- UL, C-UL Safety and ANSI/NSF7 Standards (US & Canada) \*\*

\*\* C-UL is Underwriters Laboratories Safety Certification Mark which indicates that UL has tested the equipment to applicable CSA Standards.

\*\* UL Sanitation is Underwriters Laboratories Sanitation Mark which indicates that UL has tested the equipment to applicable NSF Standards.

\*\* For listings and approval reference information please consult: <http://volitionrefrigeration.com/listings-reference/>

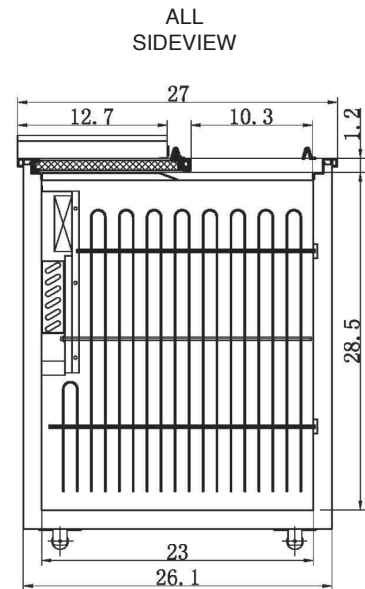
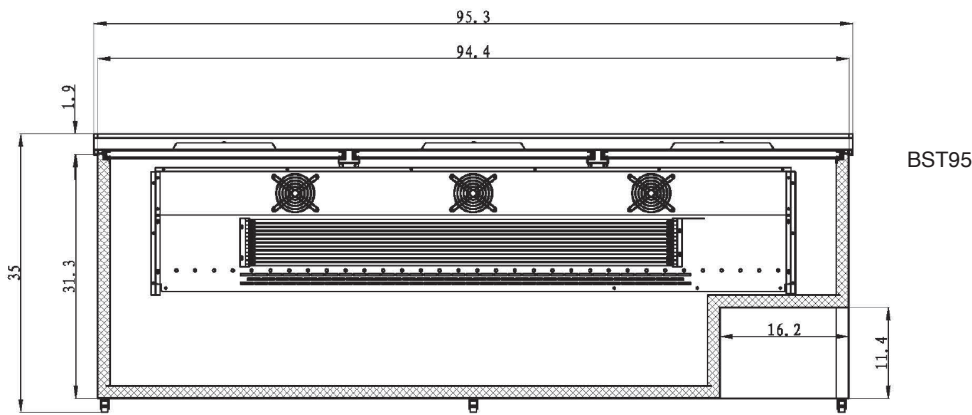
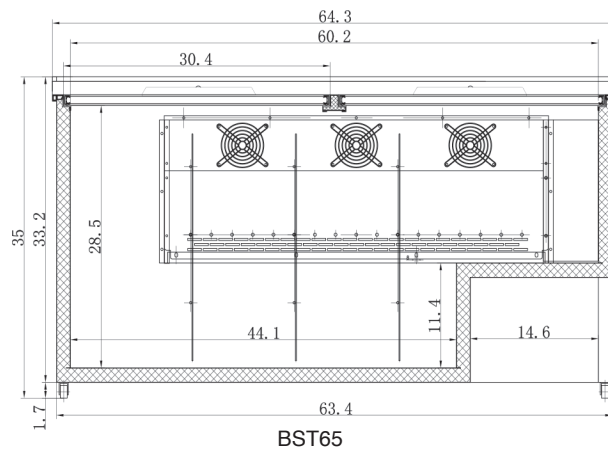
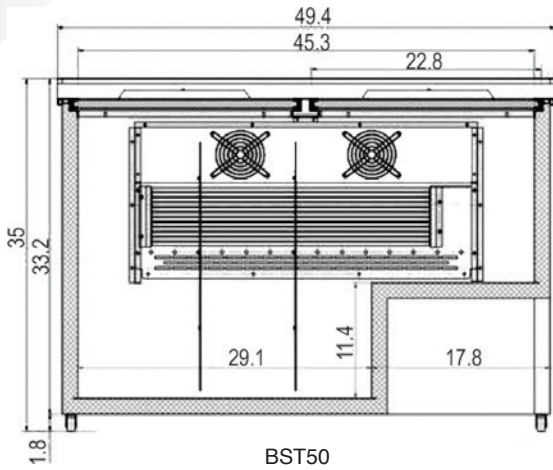

### SPECIFICATIONS

Models	BST50	BST65	BST95
Crated Weight (lbs)	309	353	439
Height (in)	35	35	35
Width (in)	49.4	64.4	95.3
Depth (in)	27	27	27
Gross Cubage (CuFt)	15	20	26
Number of Dividers	2	3	3
Number of Lids	2	2	3
Refrigerant	R600a	R600a	R600a
Electrical Characteristics	115/60/1	115/60/1	115/60/1
HP	1/2	1/2	1/2
NEMA Plug Configuration	5-15P	5-15P	5-15P
Amp	3.0	3.0	3.0
Cord Length (ft)	8.2	8.2	8.2

Specifications subject to change without notice.

Distributed by:



Rapids Wholesale Equipment  
6201 S Gateway Dr.  
Marion, IA 52302