

## VBC Series Bottle Coolers



PROJECT:

ITEM NUMBER:

MODEL NUMBER:

### SPECIFICATIONS FOR: VBC50 and VBC65

- **Exterior Finish:** Black vinyl coated steel cabinet exterior front, sides and back with stainless steel top and sliding covers.
- **Interior Finish:** Interior galvanized walls and stainless steel floor with floor drain.
- **Insulation:** Foamed-in-place with 1-1/2" CFC free polyurethane insulation.
- **Hardware:** Standard with removable bottle opener cap catcher, integrated glass rail on rear top, easy glide sliding lids with locks. Adjustable product dividers supplied. Plastic breaker strips around door openings to limit the formation of any condensation.
- **Electrical:** 115 volt, 60 Hz, 1 phase with cord and NEMA 5-15P plug.
- **Refrigeration:** Self-contained forced air R-134a capillary tube refrigeration system. Automatic defrost and condensate evaporator requires no plumbing. Adjustable temperature control with temperature range: +34°F to +38°F.
- **Approvals:** UL, C-UL Safety and ETL Sanitation (US & Canada) \*\*

### STANDARD FEATURES

- Adjustable temperature control
- Air cooled condensing unit
- Automatic defrost and condensate evaporator
- Black vinyl coated steel exterior
- Capillary tube system
- Durable galvanized interior walls
- Removable cap catcher
- Multiple evaporator fan motors
- Stainless steel top with integrated glass rail
- Stainless steel interior floor
- Stainless steel sliding lids with locks
- Temperature range: +34°F to +38°F
- Vinyl coated product dividers
- 1 Year Parts & Labor, 5 Year Compressor Warranty
- UL, C-UL Safety and ETL Sanitation (US & Canada) \*\*

### WARRANTIES



Parts & Labor  
\*Optional 2<sup>nd</sup> year  
can be purchased



Compressor

\*\* C-UL is Underwriters Laboratories Safety Certification Mark which indicates that UL has tested the equipment to applicable CSA Standards.

\*\* UL Sanitation is Underwriters Laboratories Sanitation Mark which indicates that UL has tested the equipment to applicable NSF Standards.

\*\* For listings and approval reference information please consult: <http://volitionrefrigeration.com/listings-reference/>

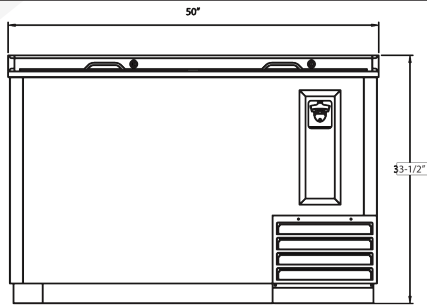

VBC50  
FRONTVIEW

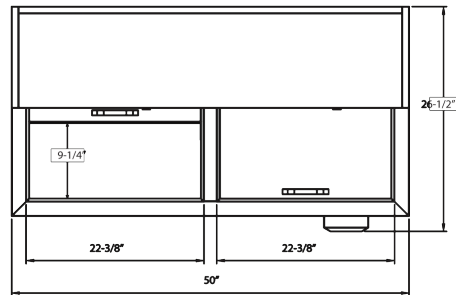

VBC50  
TOPVIEW

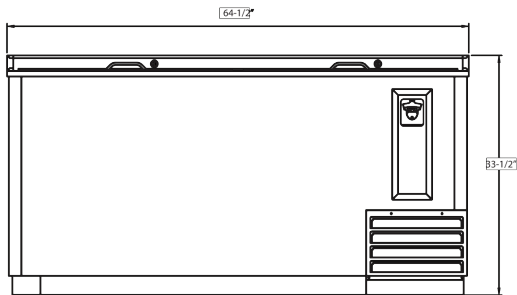

VBC65  
FRONTVIEW

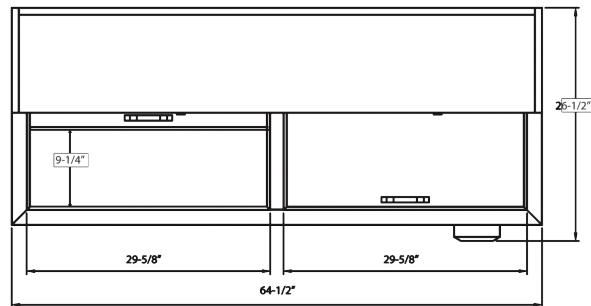

VBC65  
TOPVIEW

## SPECIFICATIONS

Models	VBC50	VBC65
Crated Weight (lbs) (kg)	260 (118)	310 (141)
Crated Height (in) (cm)	41 (104)	41 (104)
Crated Width (in) (cm)	52-1/2 (133)	67 (170)
Crated Depth (in) (cm)	29-1/8 (74)	29-1/8 (74)
Interior Height (in) (cm)	27-7/8 (71)	27-7/8 (71)
Interior Width (in) (cm)	46 (117)	60-1/2 (154)
Interior Depth (in) (cm)	22-3/4 (58)	22-3/4 (58)
Overall Height (in) (cm)	33-1/2 (85)	33-1/2 (85)
Overall Width (in) (cm)	50 (127)	64-1/2 (164)
Overall Depth (in) (cm)	26-1/2 (67)	26-1/2 (67)
Gross Cubage (CuFt) (L)	14.8 (419)	20.1 (569)
Number of Dividers	3	4
Condensing Unit Size	3/8 HP	3/8 HP
Refrigerant	R-134a	R-134a
Electrical Characteristics	115/60/1	115/60/1
Cord & Plug Furnished	Yes	Yes
NEMA Plug Configuration	5-15P	5-15P
Total Amp Draw	6.1	6.1
12 oz. Can Capacity	857	1191
12 oz. Bottle Capacity	377	539

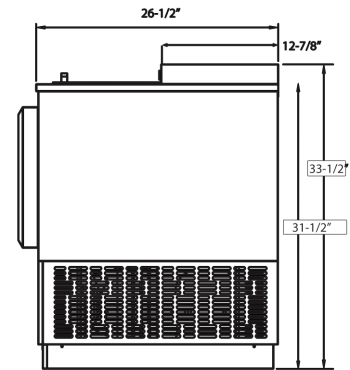

ALL  
SIDEVIEW

## OPTIONAL ACCESSORIES

- Additional 2nd year parts & labor warranty
- Caster Kits

Distributed by:



Rapids Wholesale Equipment  
6201 S Gateway Dr.  
Marion, IA 52302

Specifications subject to change without notice.

\* Floor drain connection exits the rear of the cabinet condensing unit compartment.